

**UYGULAMALI GİRİŞİMCİ  
TASARIMCI WORKSHOP**

6 ŞUBAT - 4 MART



Workshop Yürütücüsü:

**Kunter Şekercioğlu**

IMOS adına

**Büşra Yavuz**

PDF Katalog Tasarım ekibi:

**Cansu Salcı**

**Ebrar Ülker**

Danışman/ I'm Design:

**Eyüp Atalay**

Fotoğraf çekimi & styling destek:

**Asuman Beyza Uzun**

**Cansu Salcı**

**Ebrar Ülker**

**Furkan Şimşek**

**Öykü Sıla Salkım**

**Özcan Düzce**

**Rabia Üçüncü**

Teknik Kolaylaştırıcı:

**Gözde Şekercioğlu**

Katılımcılar

- Alp Buldanlıoğlu
- Asuman Beyza Uzun
- Cansu Salcı
- Ebrar Ülker
- Erva Nurçin Şenay
- Ezgi Dünyaadamı
- Furkan Şimşek
- Görkem Er
- Hale Nur Tuncay
- Halime Şule Göçer
- Kübra Şen
- Muazzez Çomak
- Öykü Sıla Salkım
- Özcan Düzce
- Rabia Üçüncü
- Şeyma Yıldırım
- Ünal Özsoy

# KUNTER ŞEKERCİOĞLU

Workshop Yürütücüsü

Bu sene 7.si düzenlenen I'M DESIGN etkinliği mecburen pandemi koşullarında organize edildi. Geçmiş senelerde çalıştaylar İnegöl'de gerçekleşir ve dernek katılımcı öğrencileri ağırlar, fabrika ziyaretleri yapılır ve bir hafta boyunca kalabalık şekilde birlikte çalışmanın keyfine varılırdı. Bu sene mecburen yeni koşullara adapte olduk ve çalıştay bir aylık bir süreye yayarak çevrimiçi organize ettik.

Bir kaç ay sonra profesyonel hayata geçerek meslektaşım olacak öğrencilere, tasarımcının girişimci olduğu bir süreci deneyimlettirmeyi planladık. Çalışma alanlarında özgür kaldılar ama gerçekçi şekilde malzeme seçimi ve üretim yönteminde limitlerle tanıştılar. Belki de kendi markalarının ilk ürünü olacak tasarımlarını çalışırken; iş-zaman planına uymanın önemini, trend ve pazar analizi yapmayı, genelde gözardı edilen eskiz ve maketle çalışmanın sürece katkısını, üretim için data hazırlamanın 0.02 mm'lik hassasiyetini,

malzemenin huyu-suyu olduğunu, sıkışık zamanlarda acil revizyon yapılmasının ne kadar normal olduğunu, detay geliştirmek kadar maliyet mukayesesinin de önemli olduğunu, montaj çizimi ve fotoğraf çekiminin sürecin parçaları olduğunu deneyimlediler.

Bu sayfalarda; her bir katılımcının, sığdırabildiğimiz kadarıyla, tasarım sürecini anlatan eskiz ve maketlerini, ardından da nihai üretimi yapılmış prototiplerinin fotoğraflarını göreceksiniz. Onların heyecanına sizin de ortak olacağınızı umuyorum.

İmos'a bana bu ışıldayan gençlerle birlikte sürece dahil olma fırsatı verdiği için, sponsorlarımıza da çalıştayımıza verdikleri tüm destekler için teşekkür ederim.

Bu dokümanın hazırlanmasındaki emeklerinden dolayı da **Cansu Salcı** ve **Ebrar Ülker**'e diğer çalıştay katılımcıları adına teşekkür ederim.

## Organizatör



## Ana Sponsor



## Sponsorlar



# Tasarım süreçleri & Prototipler

# Alp Buldanlıoğlu

Yaşar Üniversitesi

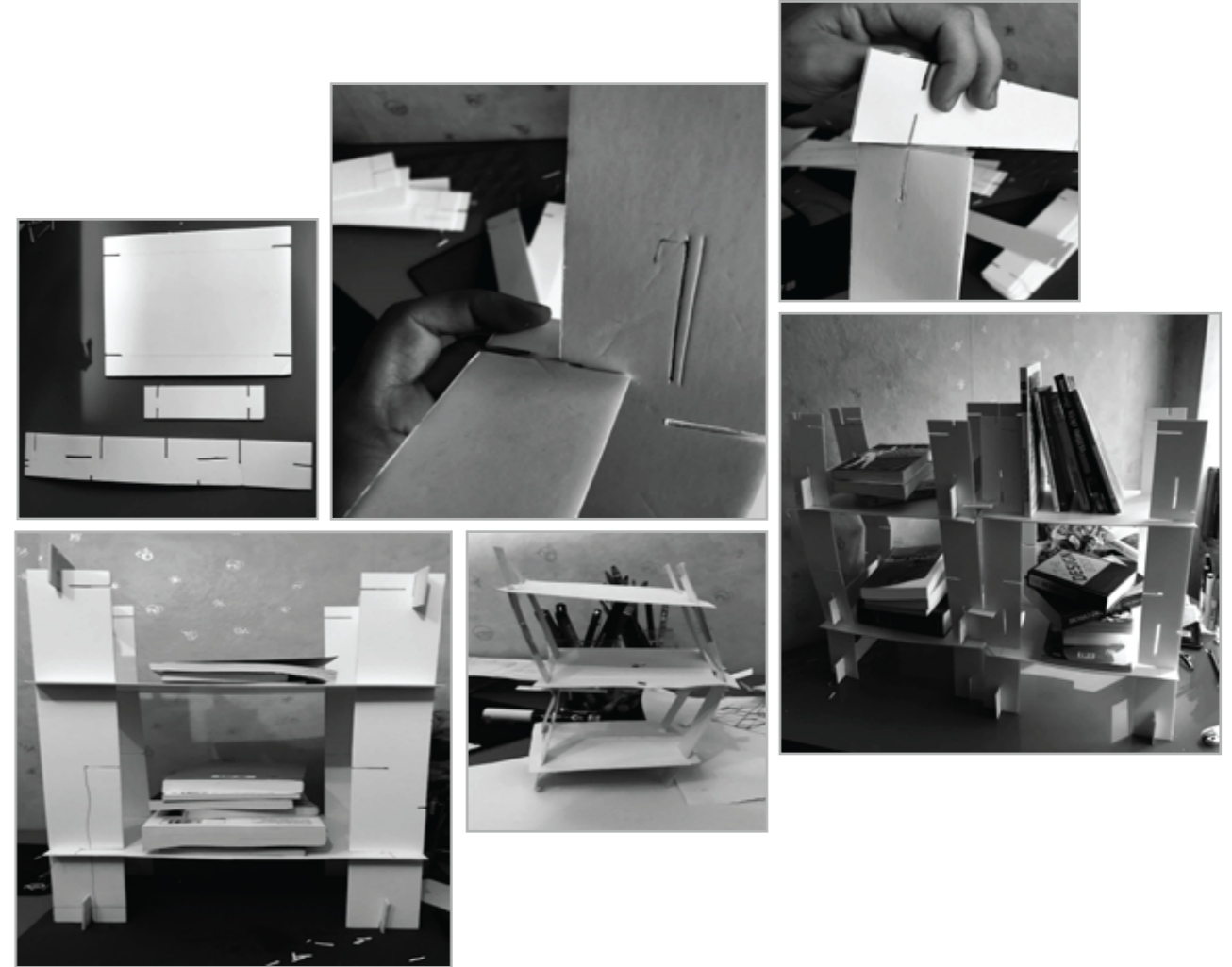
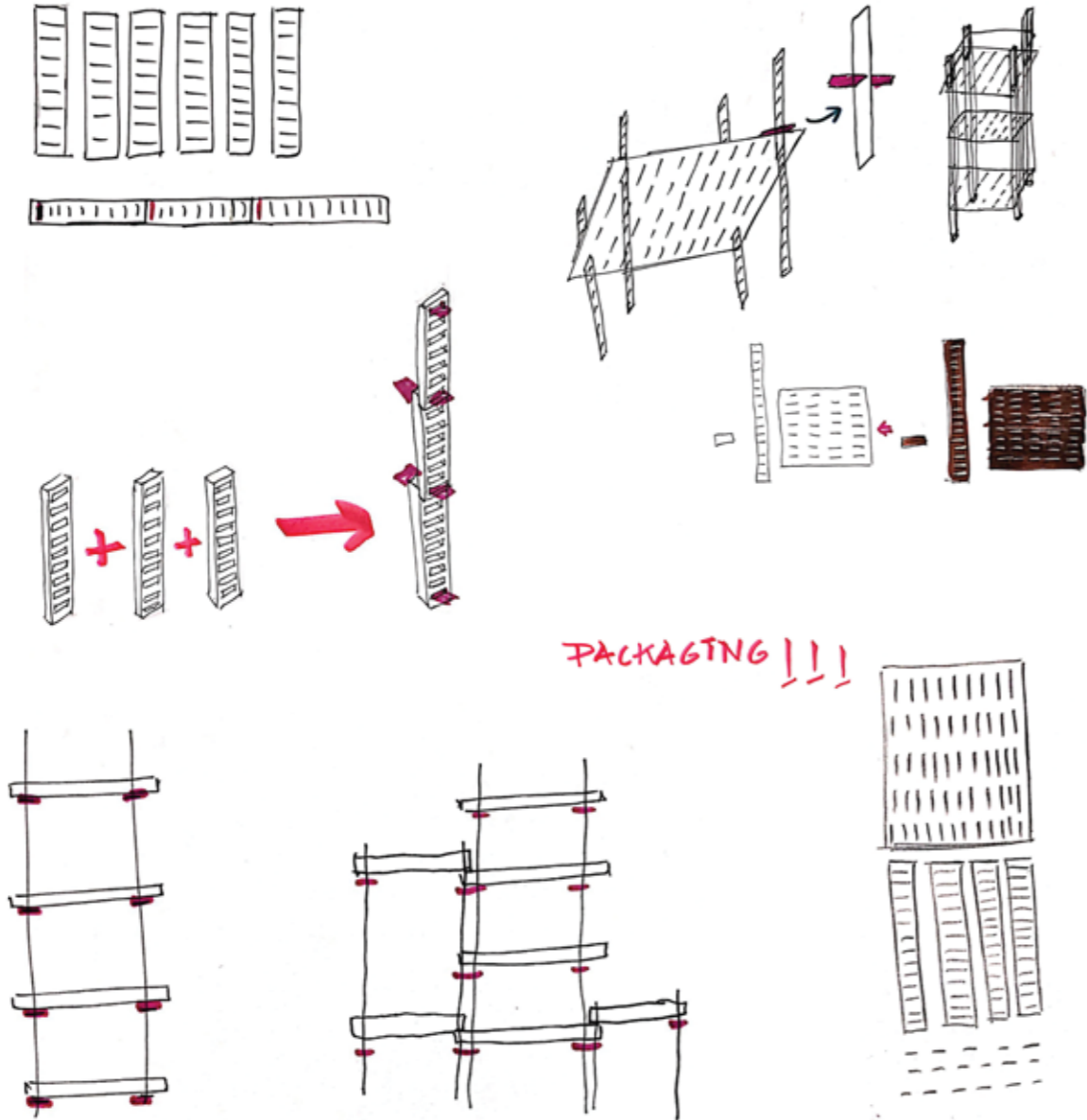



Designed by Alp Buldanlıođlu

# MÖDÜL

MODÜLER KİTAPLIK

# Asuman Beyza Uzun

Ticaret Üniversitesi

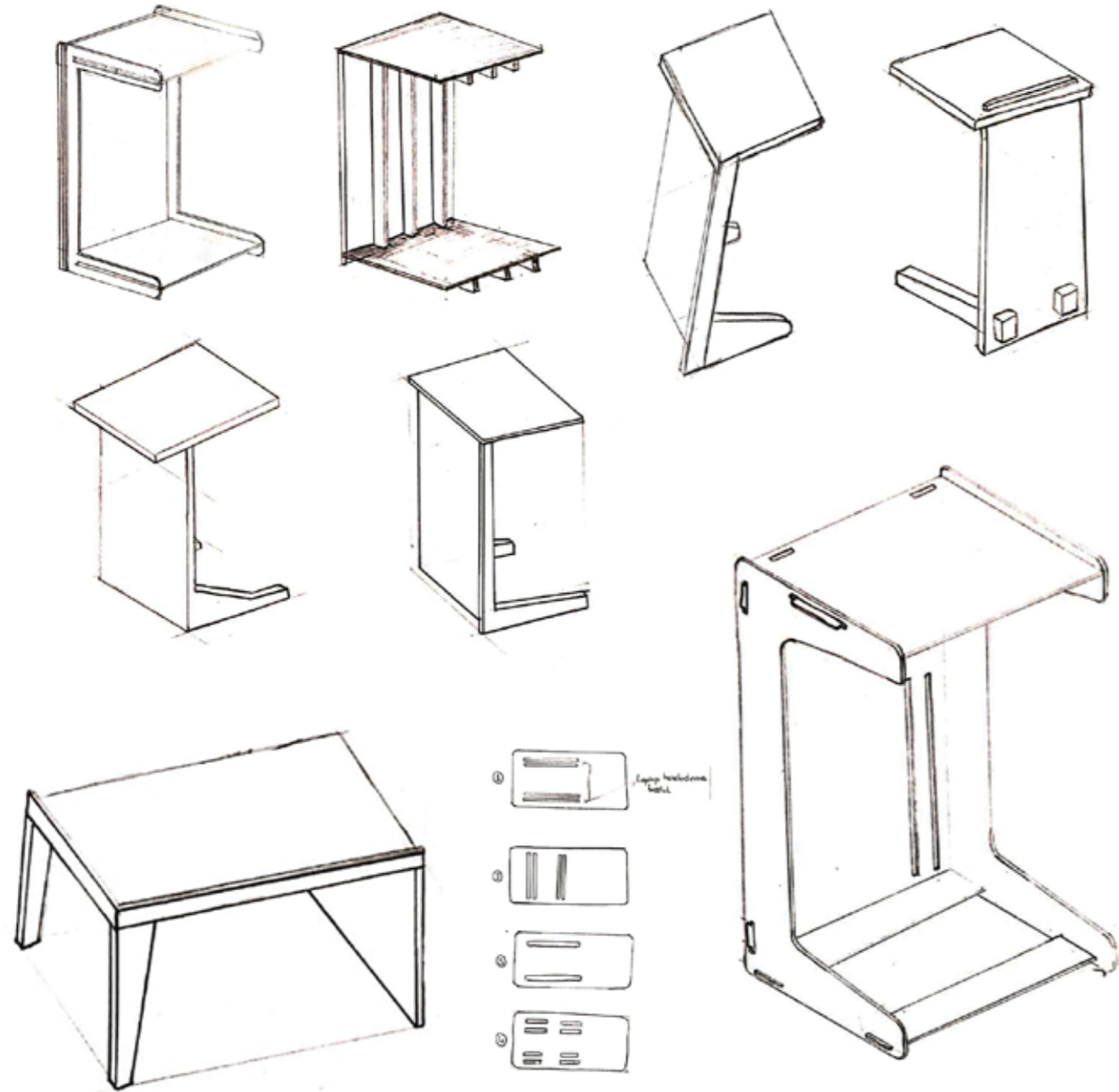



Designed by Asuman Beyza Uzun

# duoTABLE

LAPTOP SEHPASI



# Cansu Salcı

İstanbul Bilgi Üniversitesi

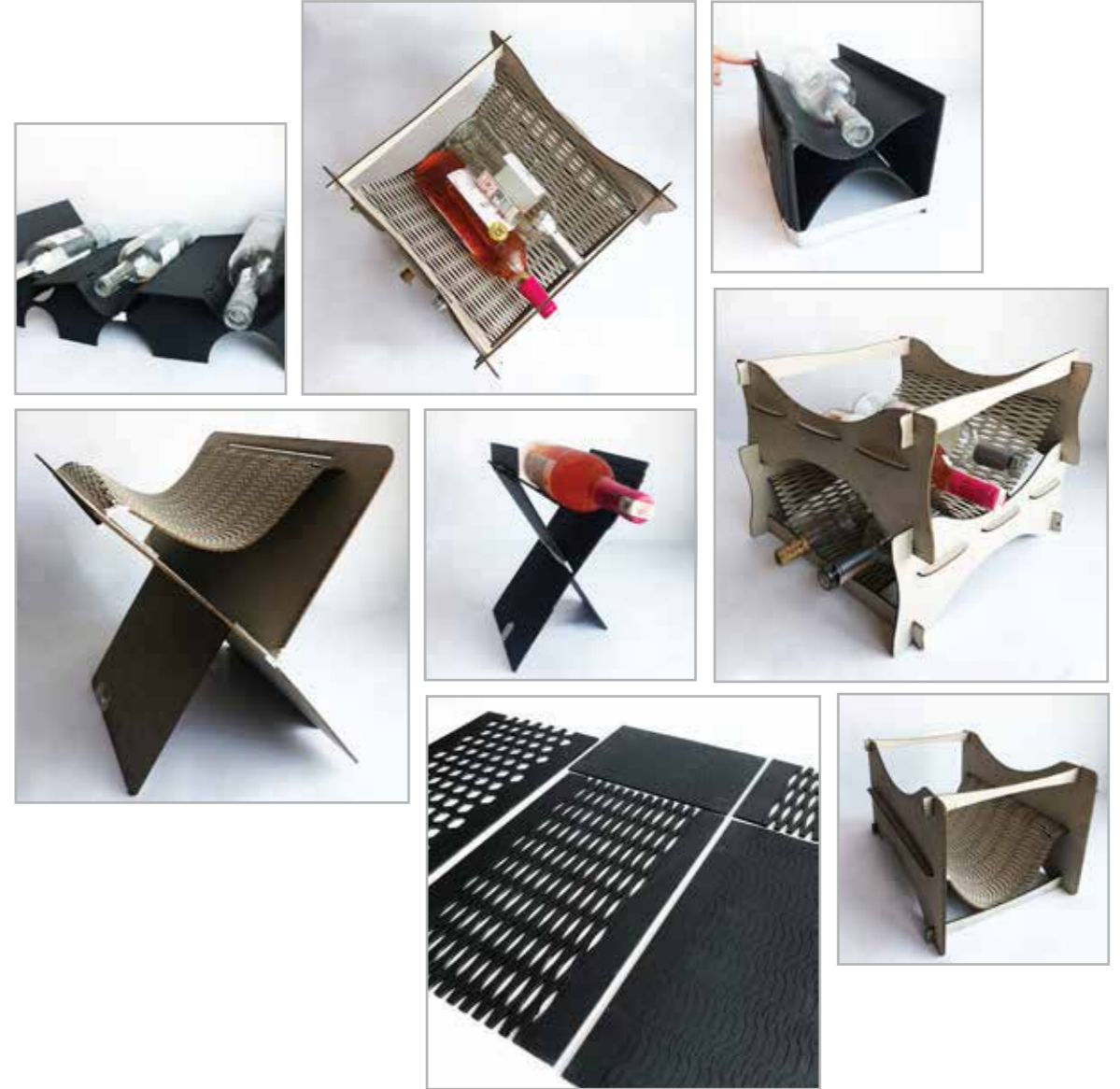
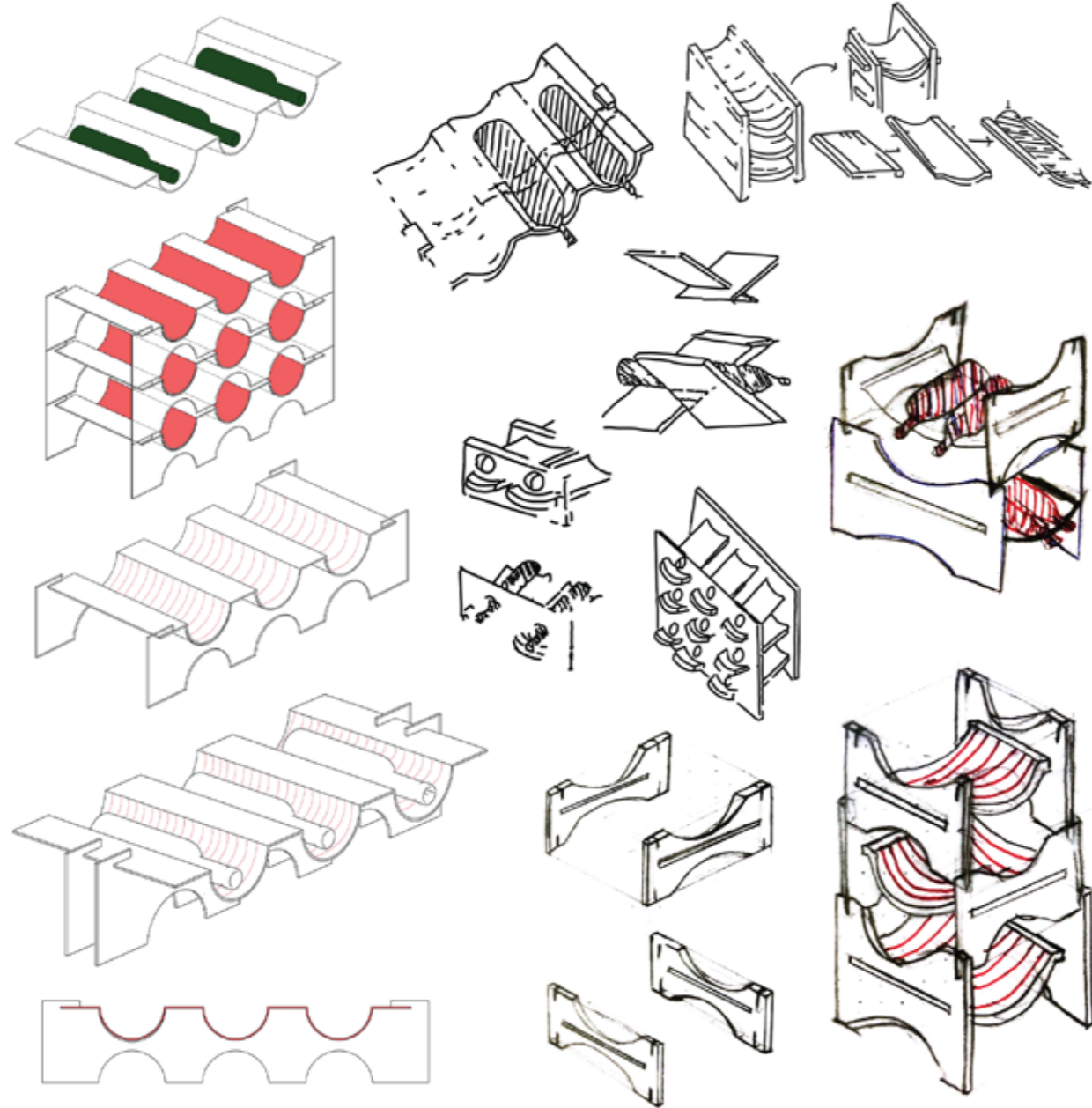



Designed by Cansu Salcı

# İSTİFÇİ

MİNİ MAHZEN

# Ebrar Ülker

Marmara Üniversitesi



2021

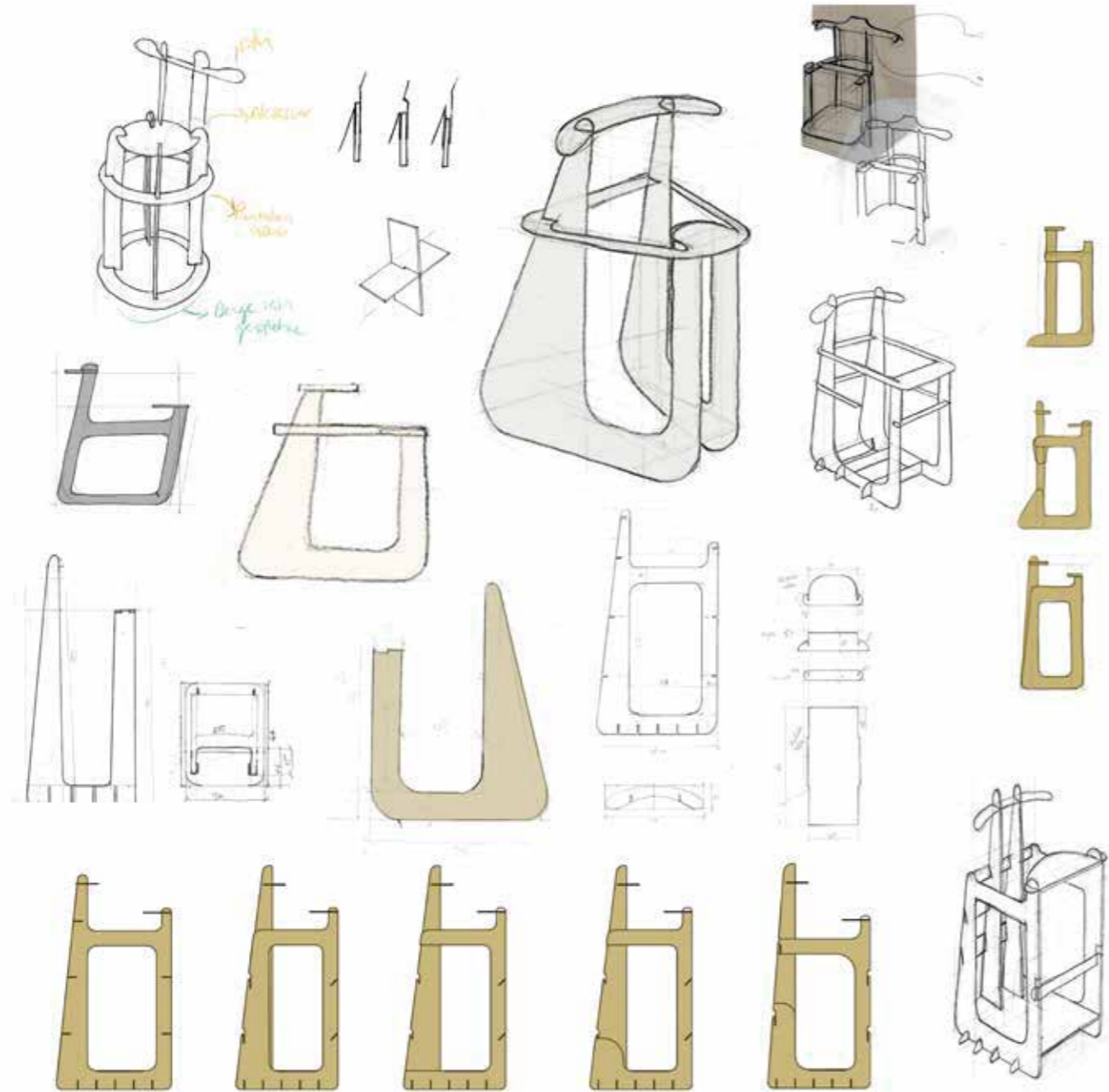



Designed by Ebrar Ülker

# SADED

DİLSİZ UŞAK

# Erva Nurçin Şenay

Selçuk Üniversitesi

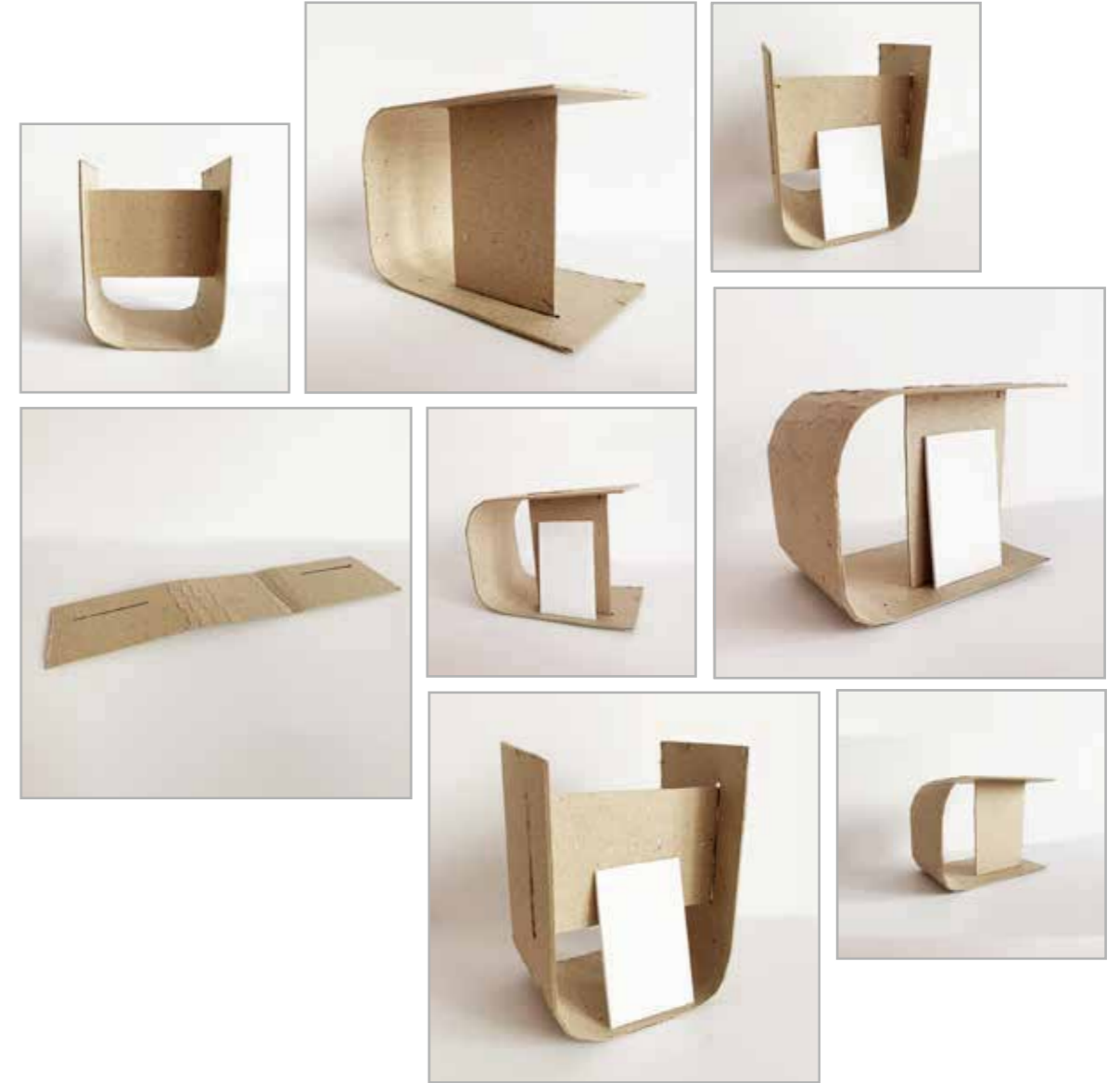
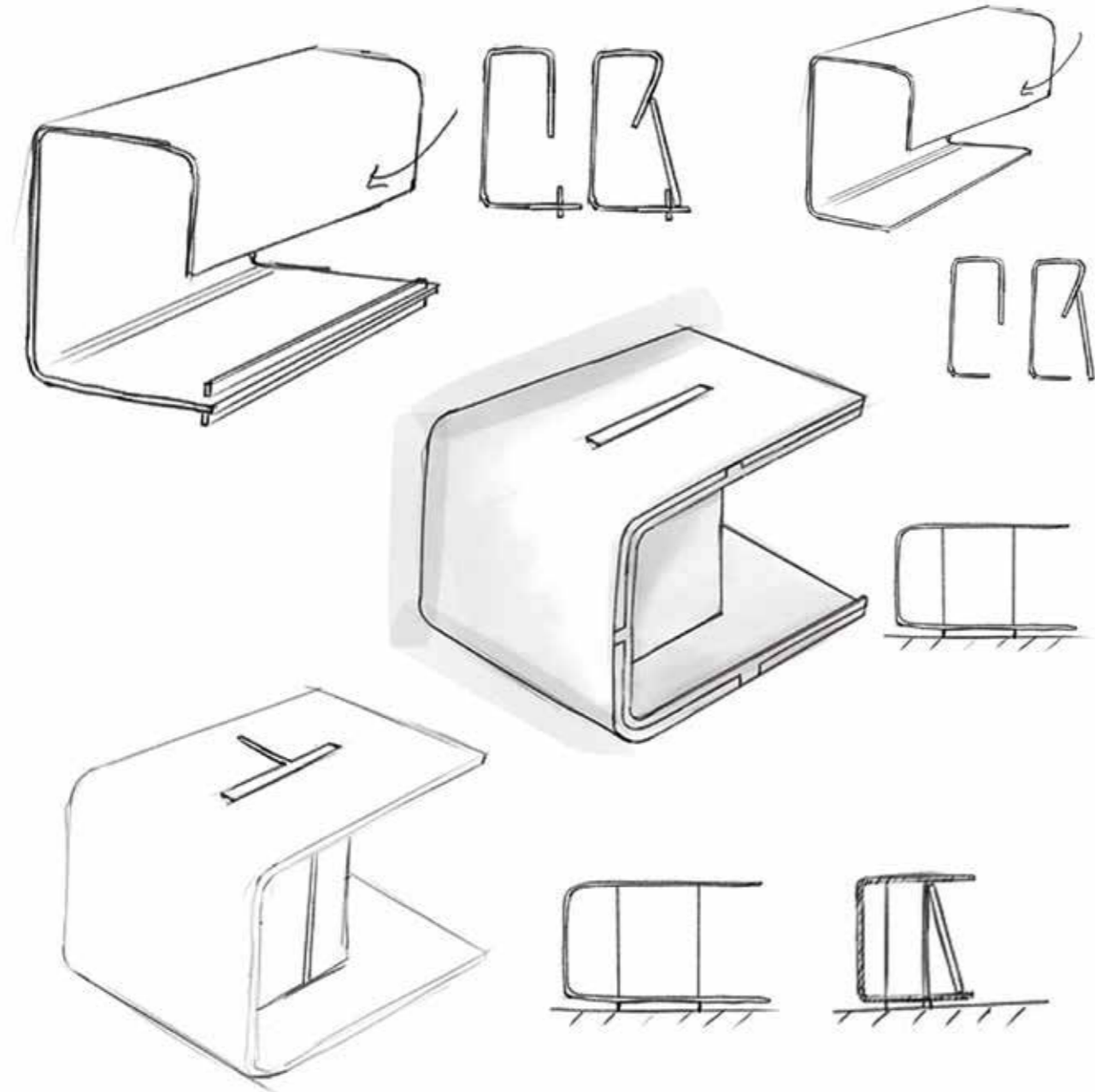



Designed by Erva Nurçin Şenay

# CURVD

MASAÜSTÜ DÜZENLEYİCİ

# Ezgi Dünyaadamı

İzmir Ekonomi Üniversitesi





Designed by Ezgi Dünyaadamı

# HOTMOOD

TEALIGHTLI KUPA ISITICI STAND



# Furkan Şimşek

Beykent Üniversitesi

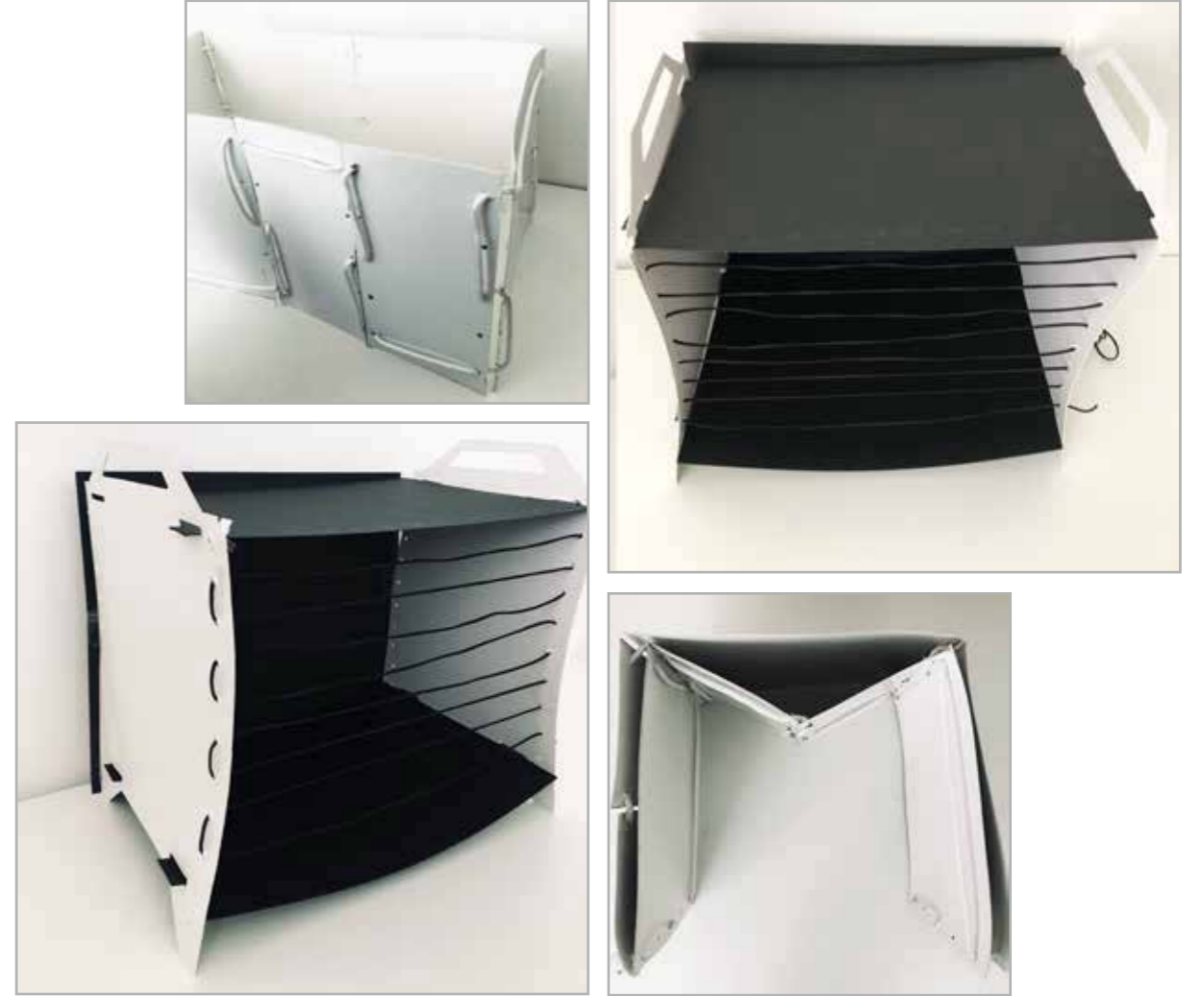
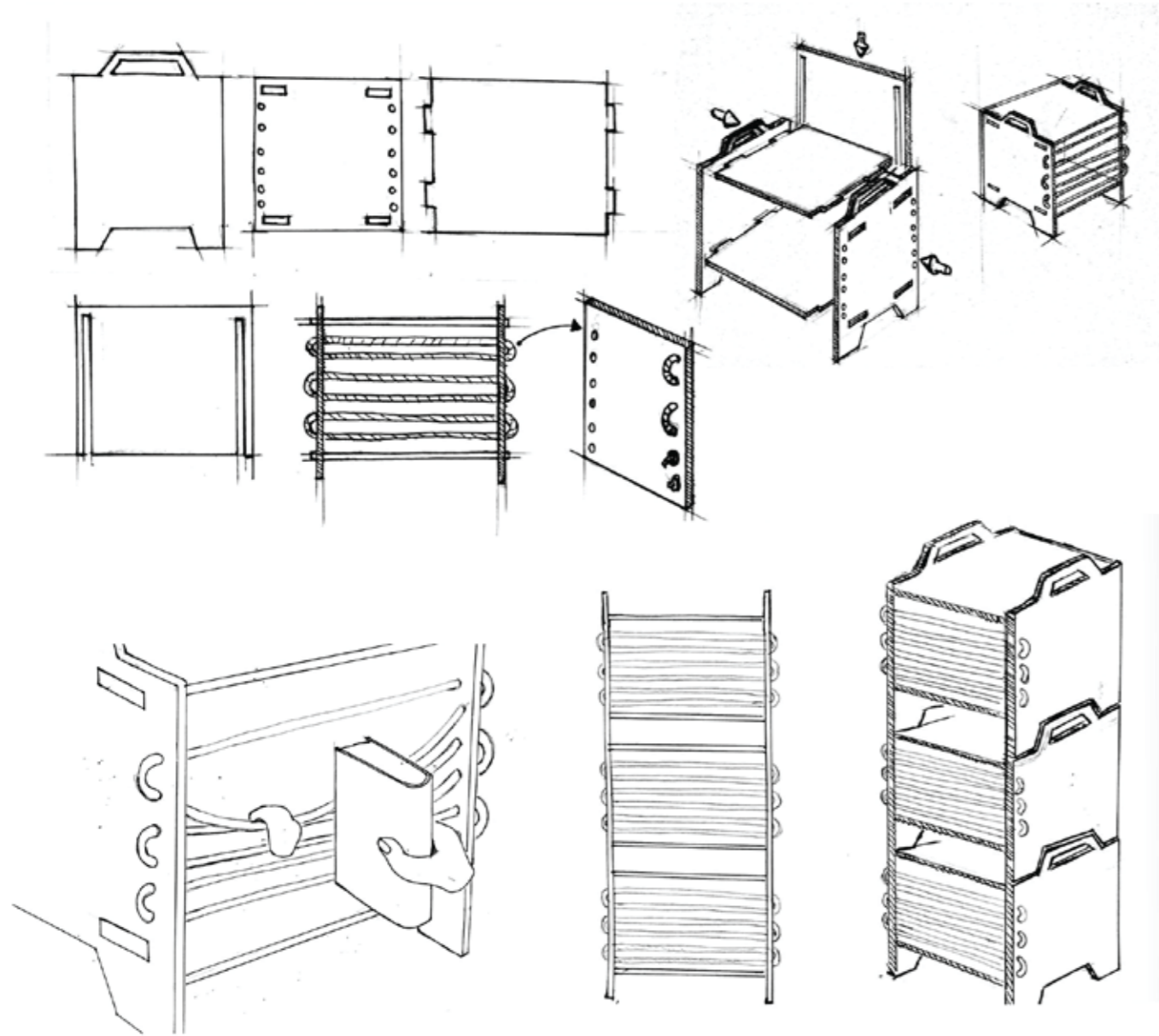

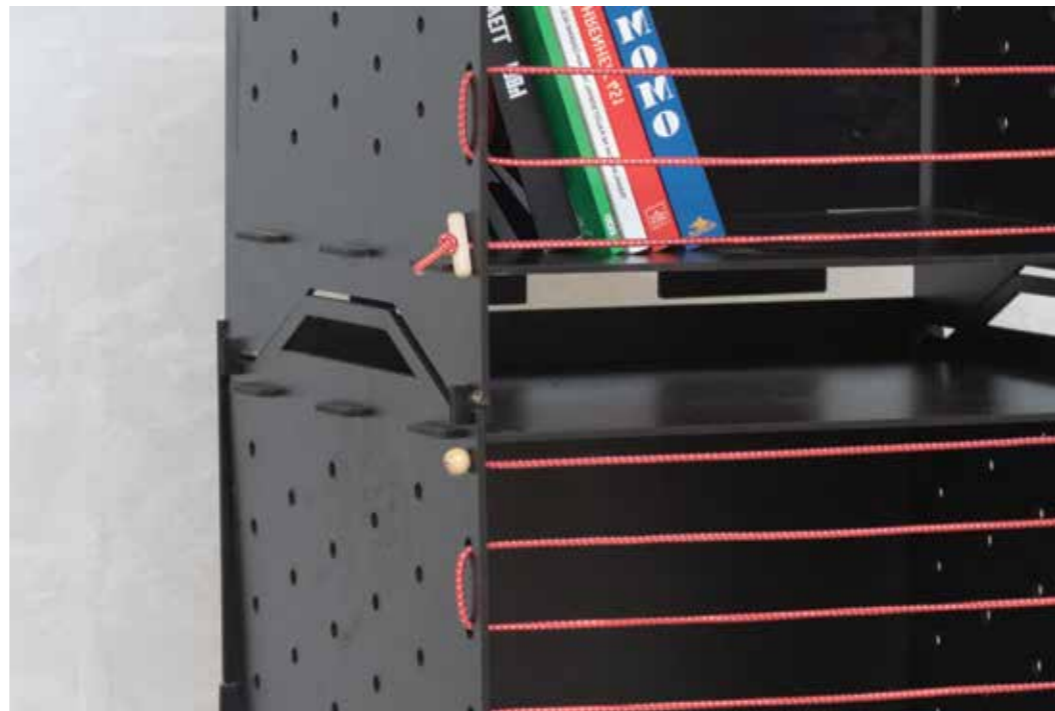

Designed by Furkan Şimşek

# ROPi

MODÜLER DEPOLAMA

# Görkem Er

İzmir Ekonomi Üniversitesi

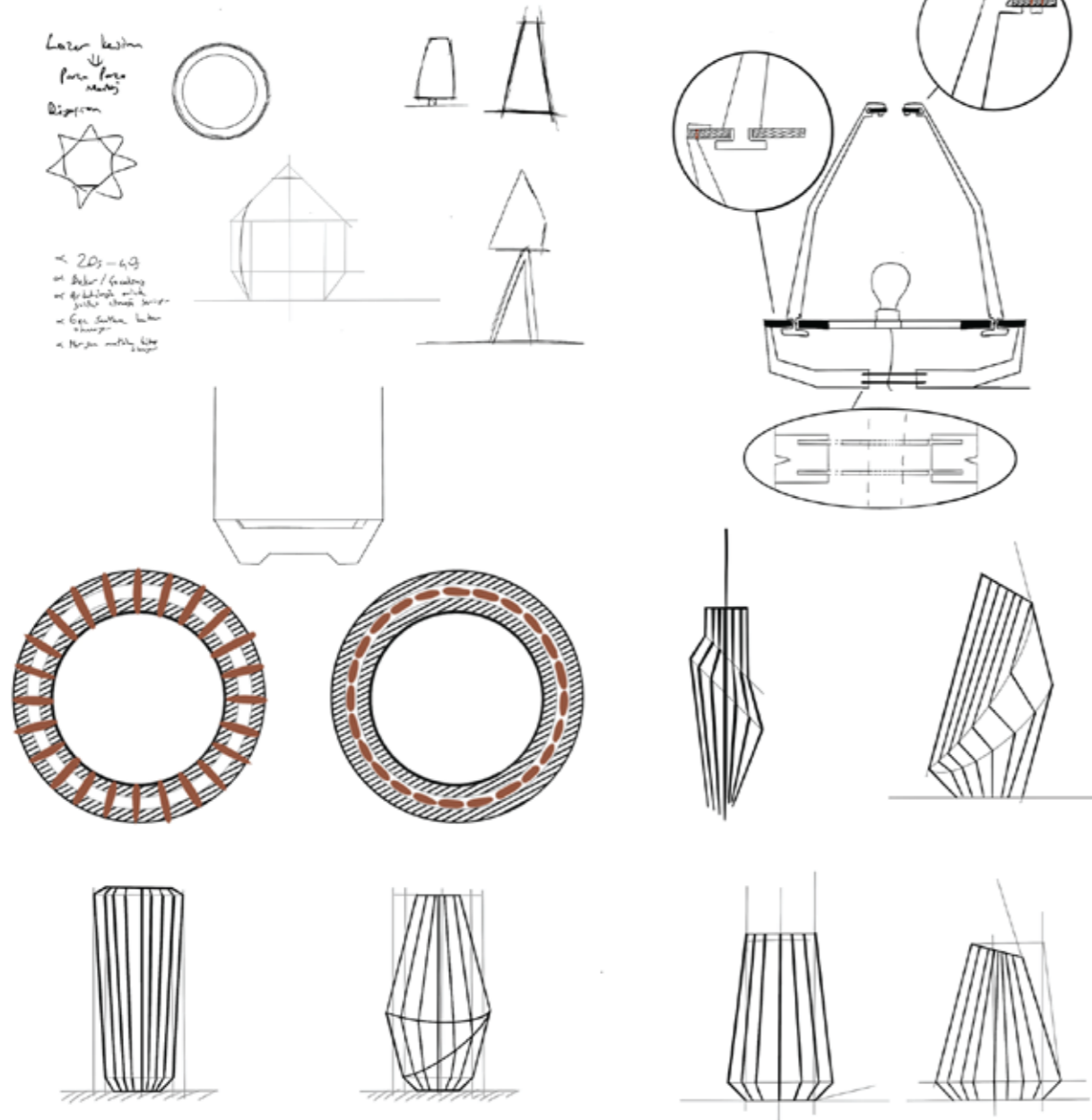



Designed by Görkem Er

# CORE

AYDINLATMA

# Hale Nur Tuncay

Karabük Üniversitesi

2021

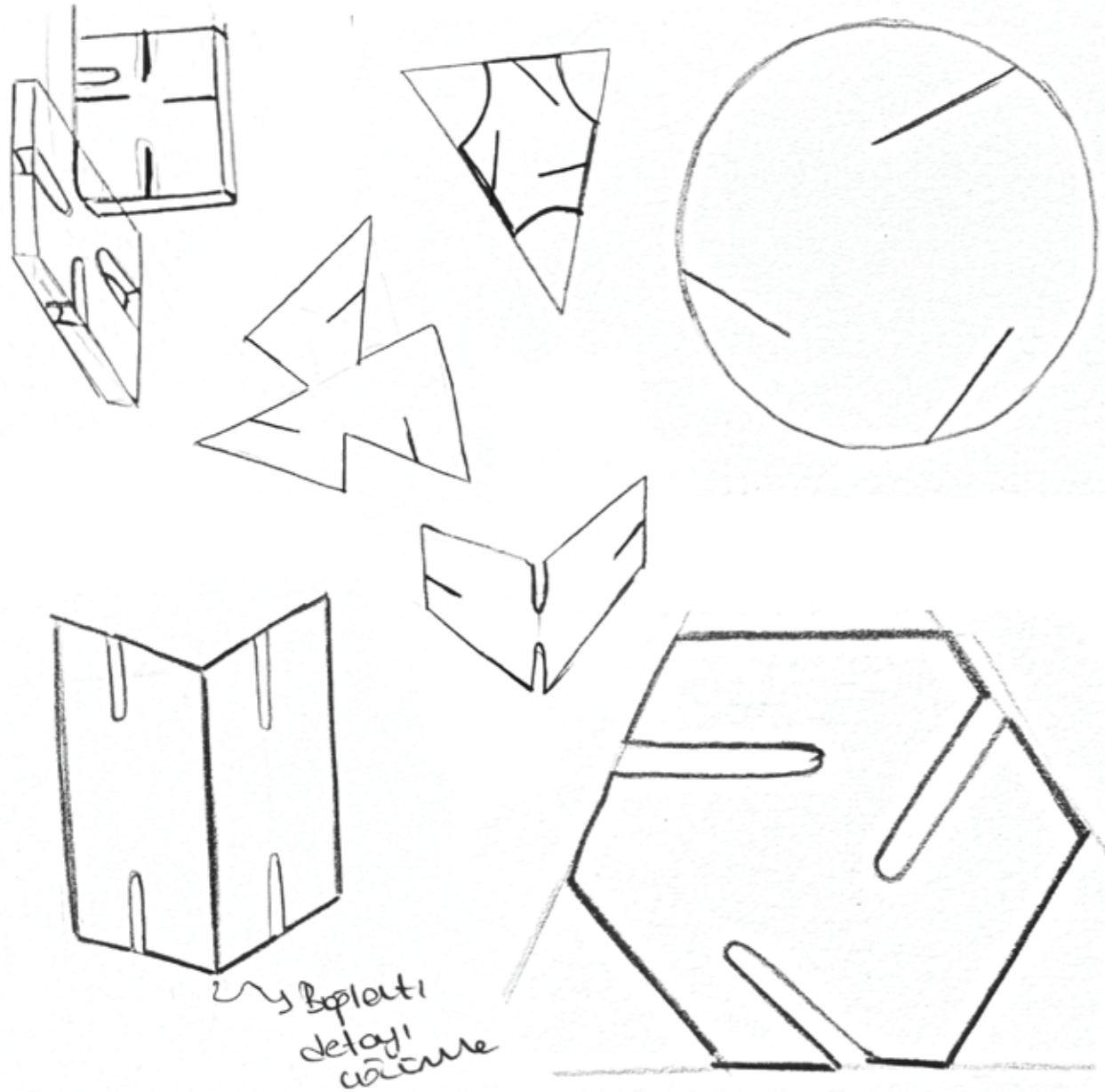



Designed by Hale Nur Tuncay

# GEAR

MODÜLER PUZZLE

# Halime Şule Göçer

Eskişehir Teknik Üniversitesi

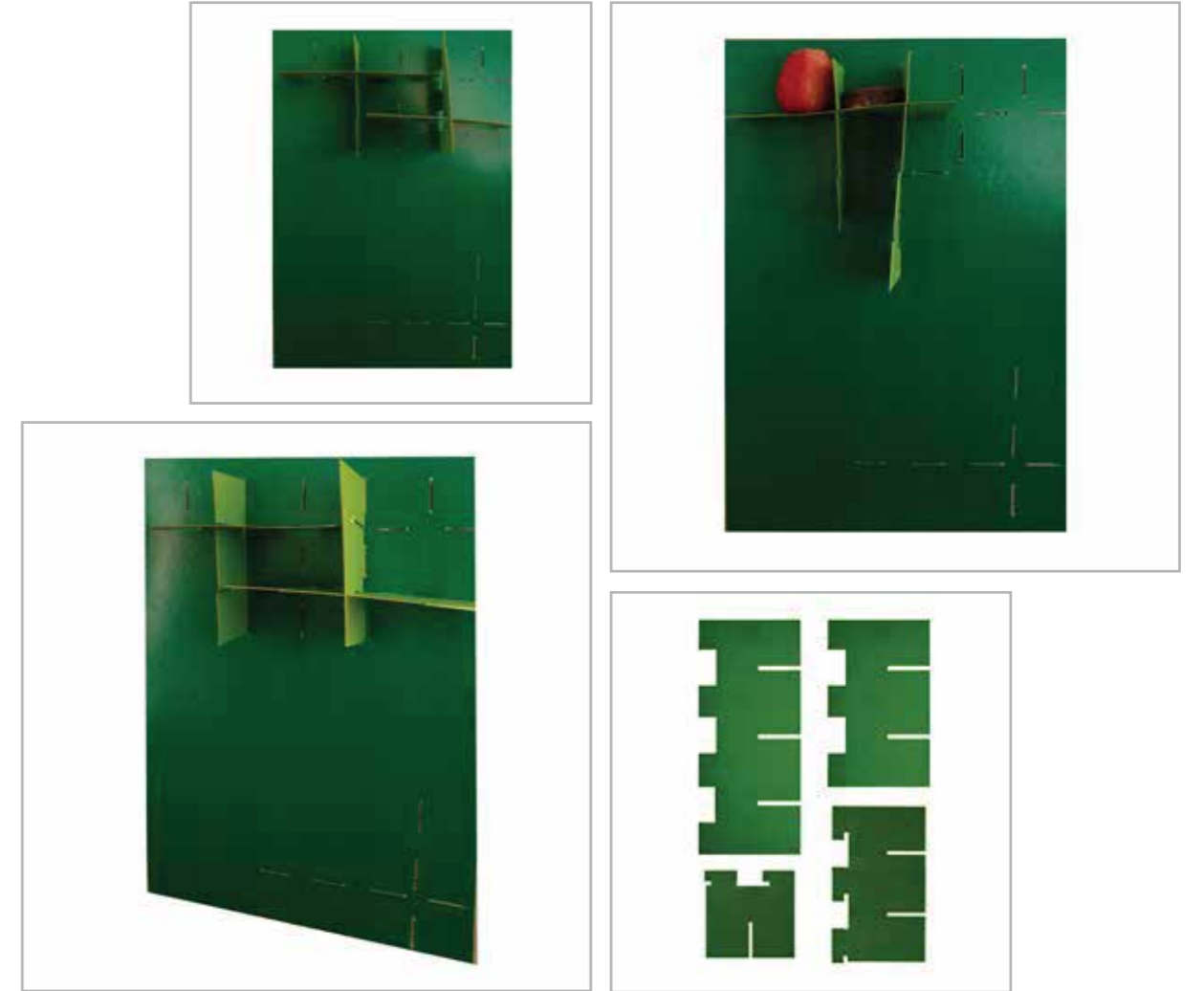
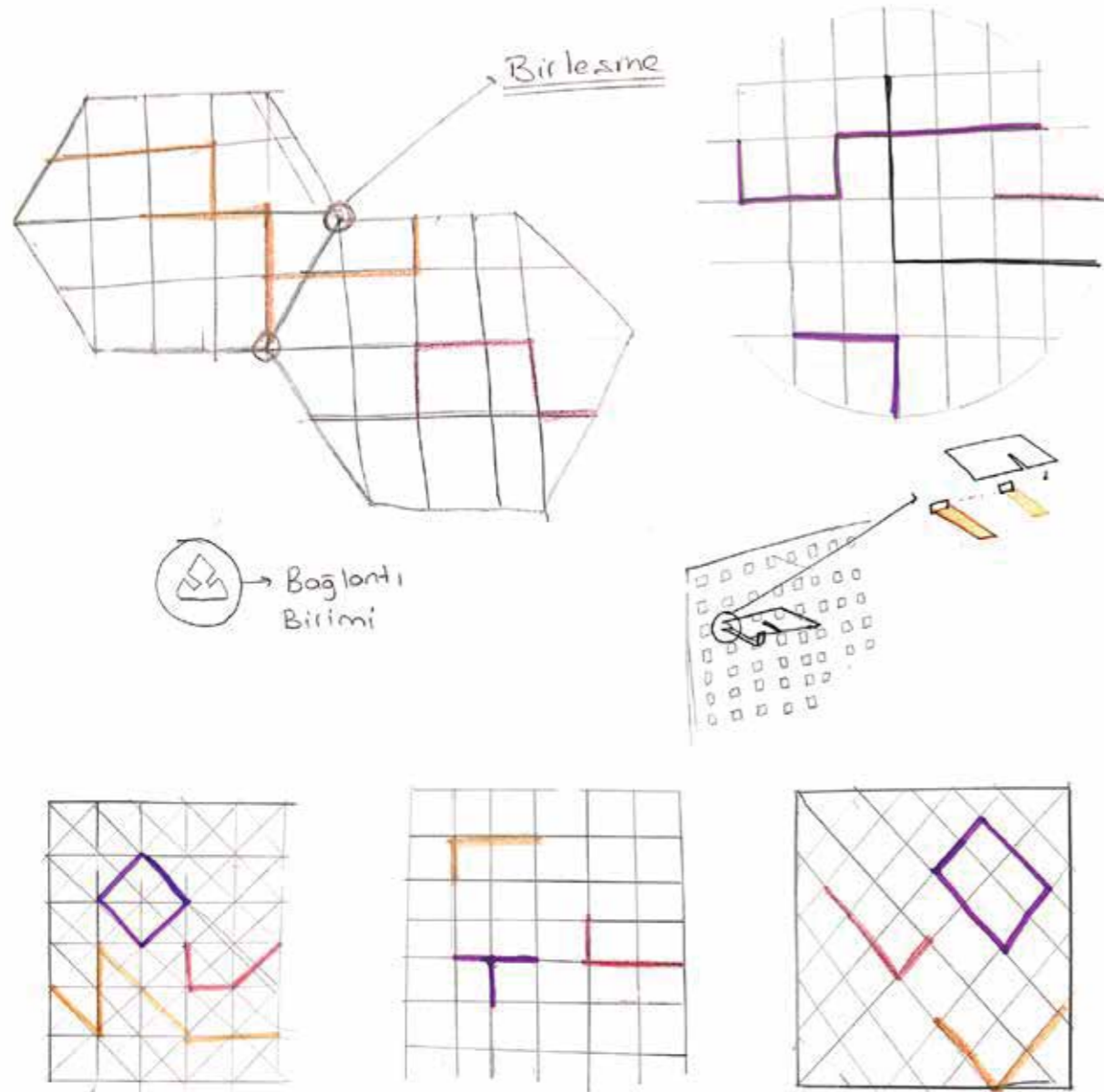

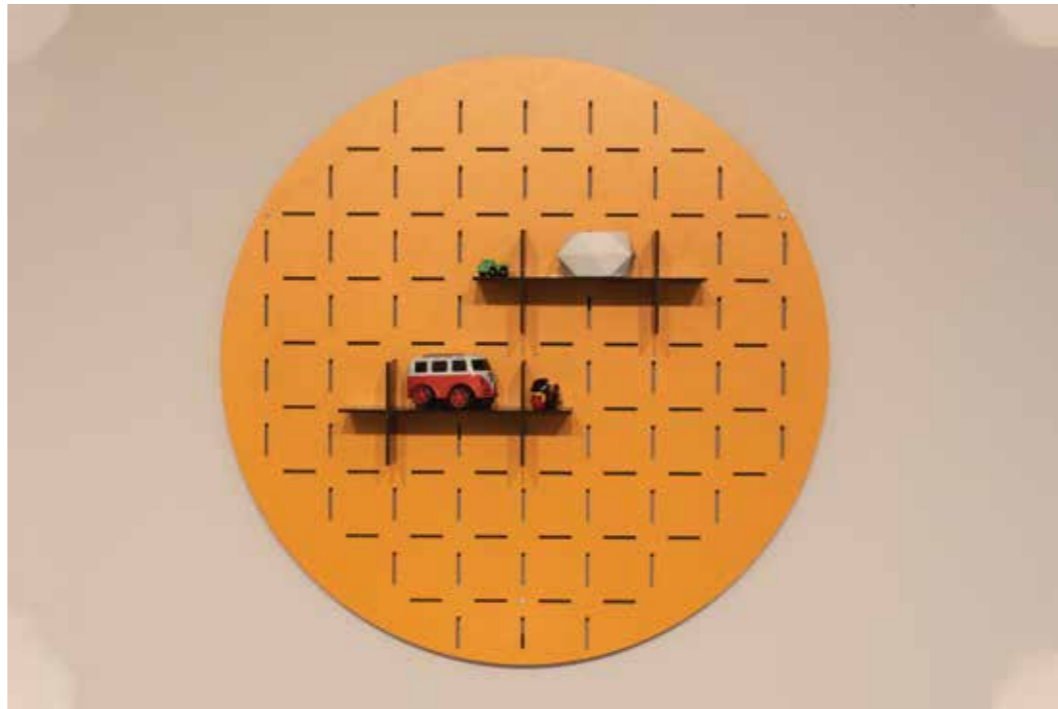
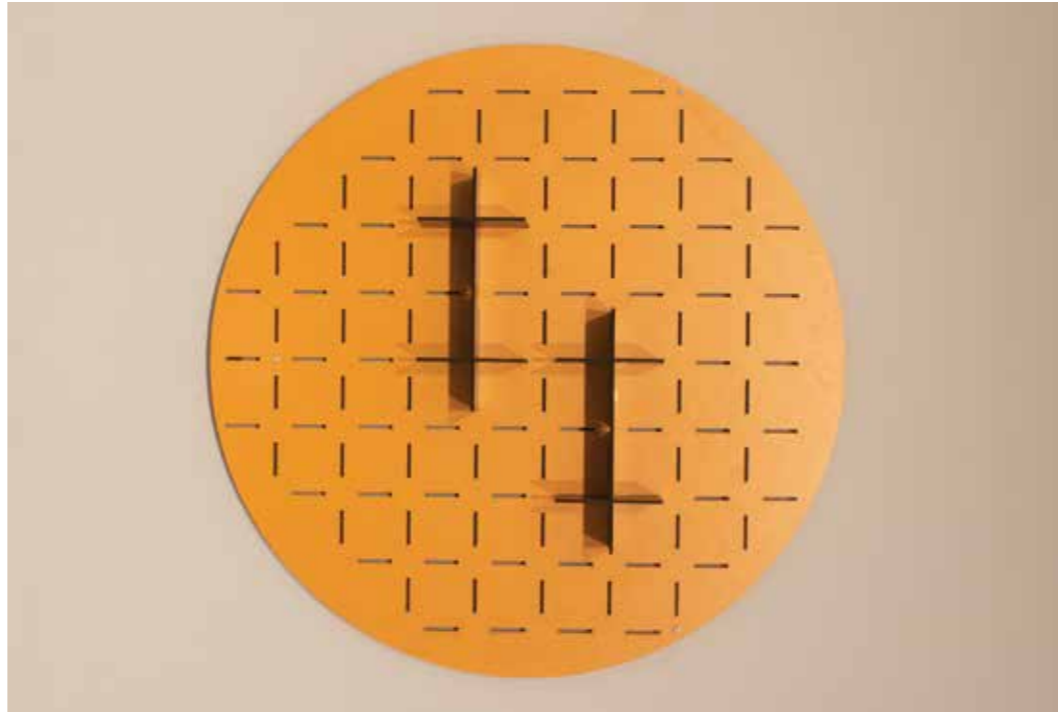
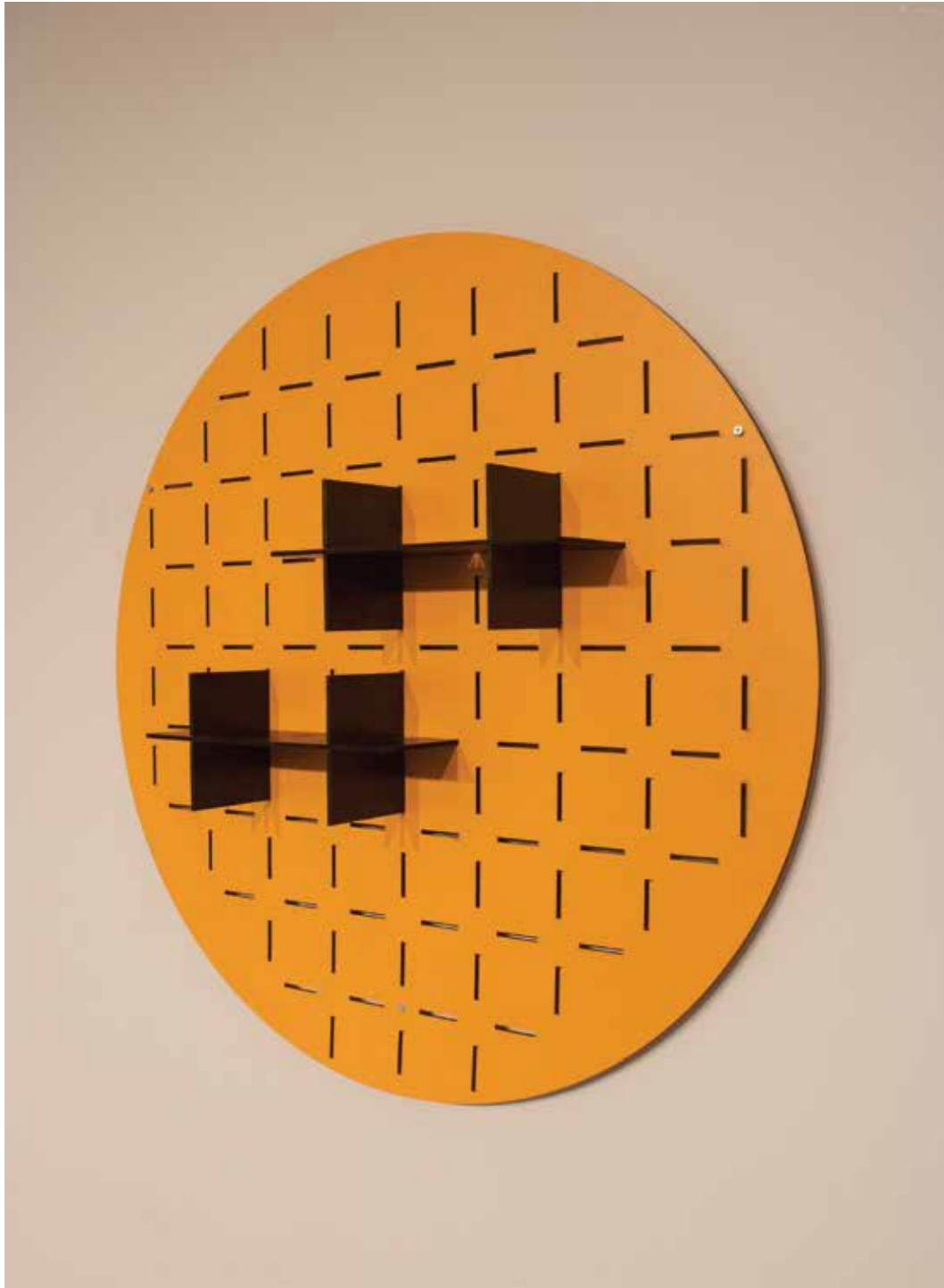

Designed by Halime Şule Göçer

# TANTE

RAFLAMA BİRİMİ



# Kübra Şen

TOBB Ekonomi ve Teknoloji Üniversitesi

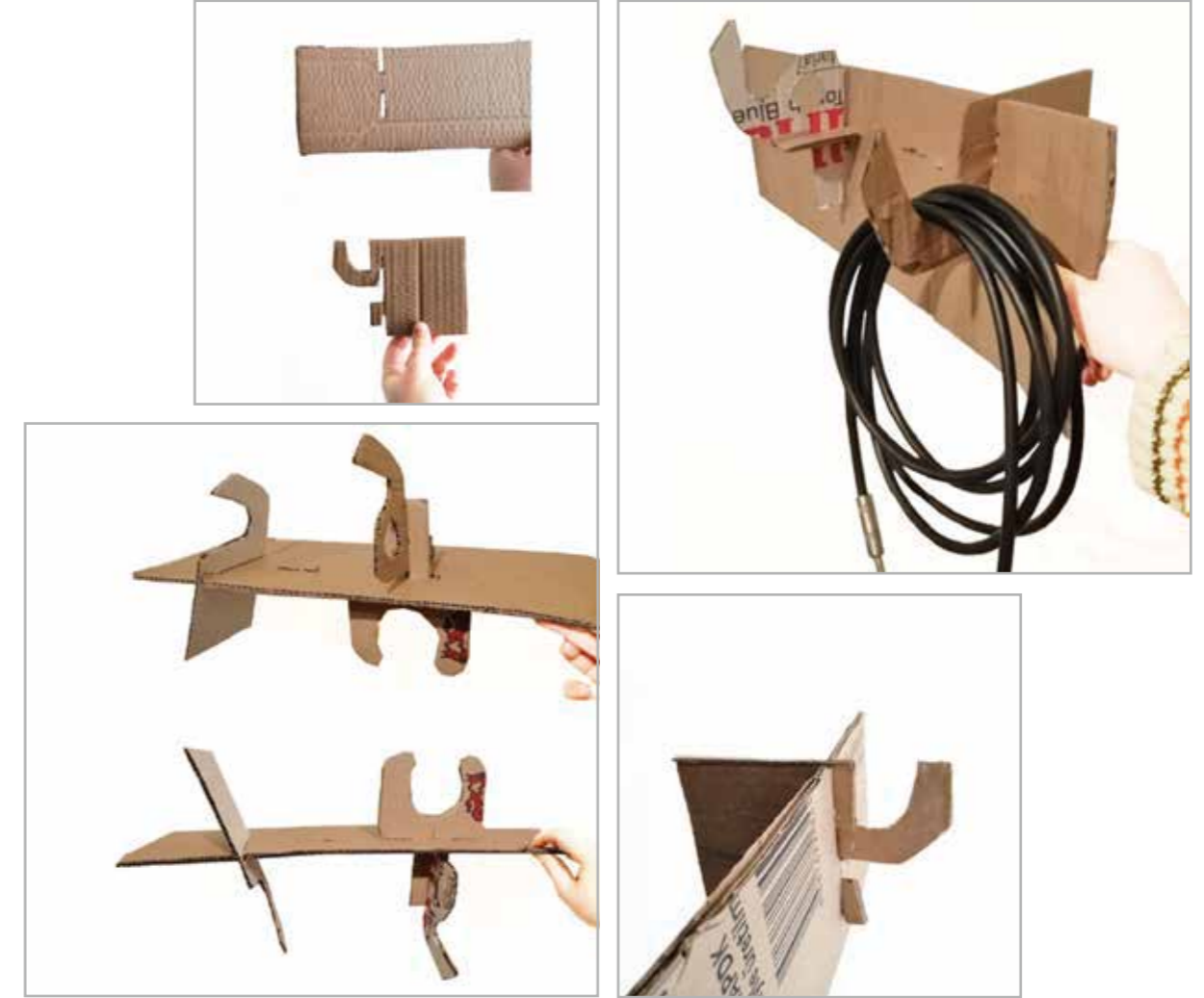
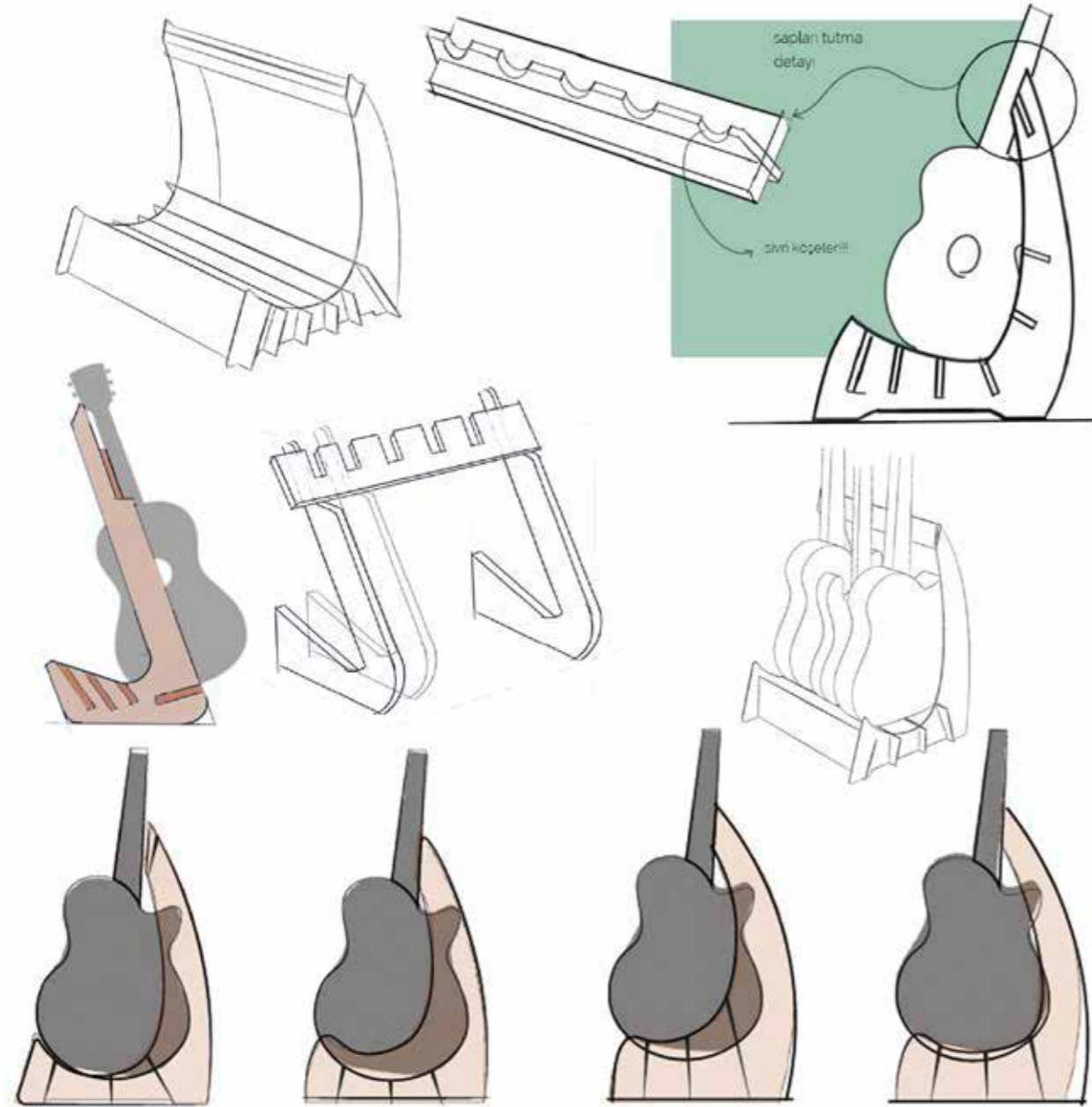



Designed by Kübra Şen

# TONIC

GİTAR STANDI

# Muazzez Çomak

Karabük Üniversitesi

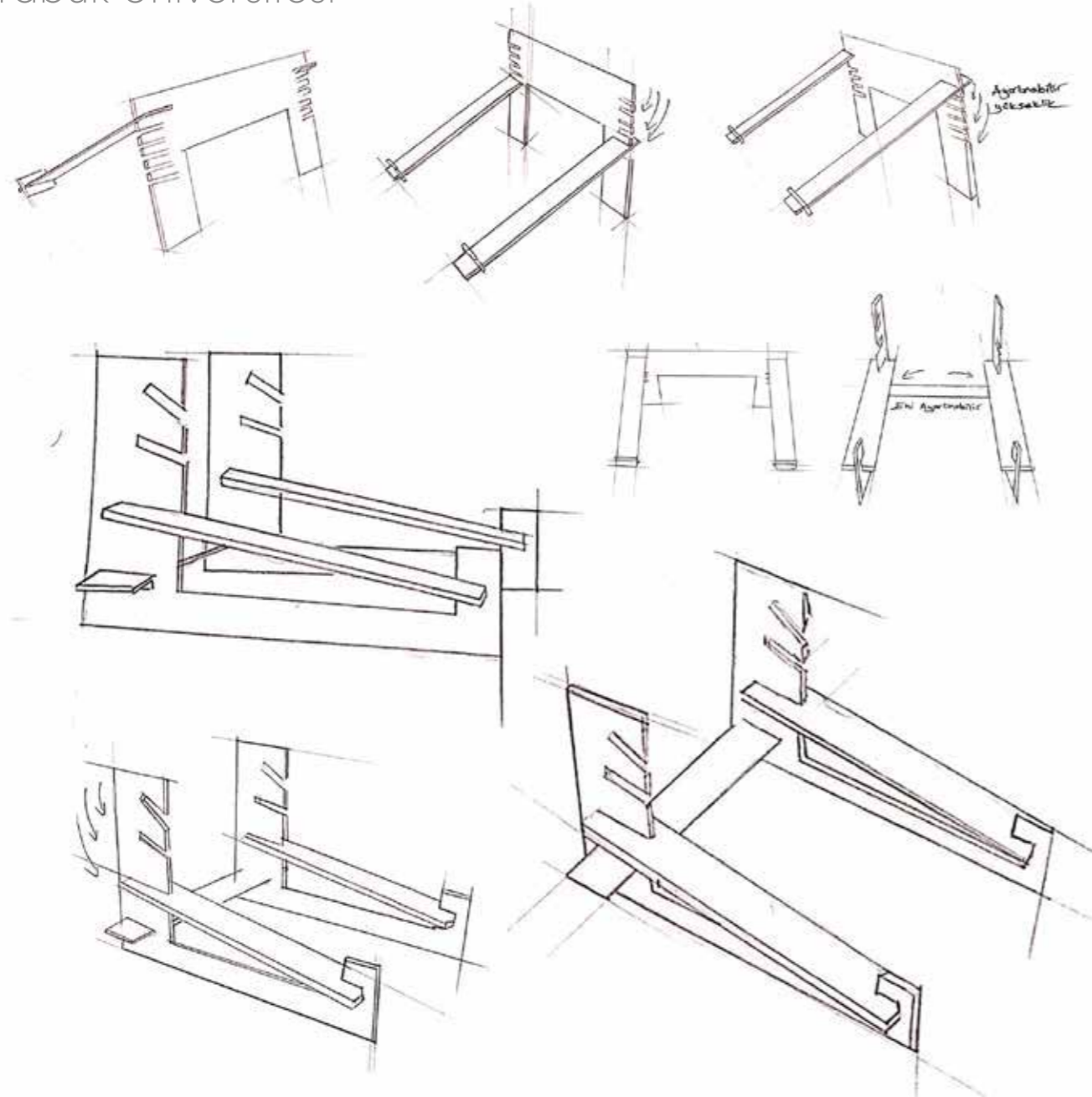



Designed by Muazzez Çomak

# BESIDE

LAPTOP YÜKSELTİCİ

# Öykü Sıla Salkım

Marmara Üniversitesi

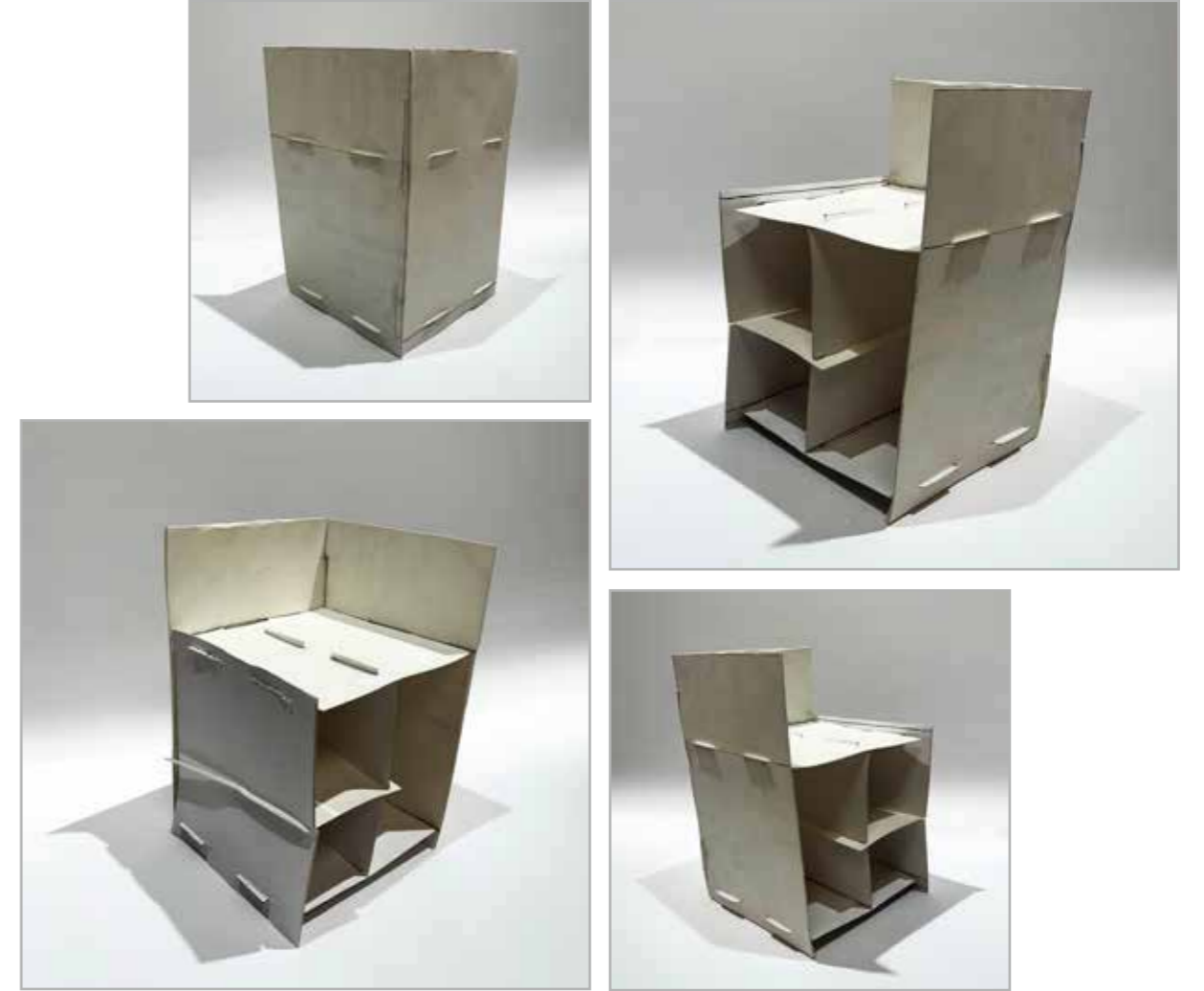
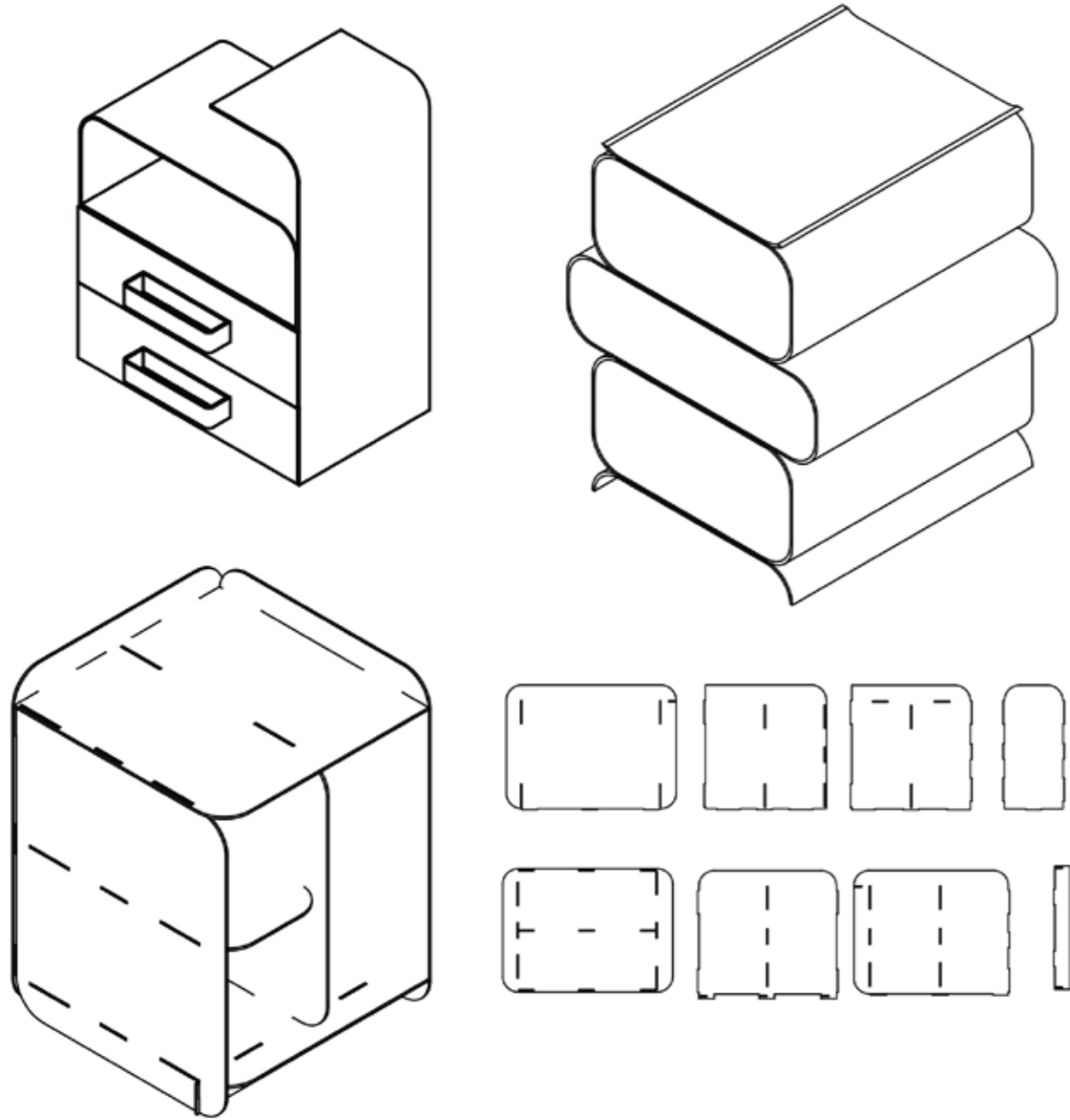



Designed by Öykü Sıla Salkım

# COMY

KOMODİN

# Özcan Düzce

Bilecik Şeyh Edebali Üniversitesi

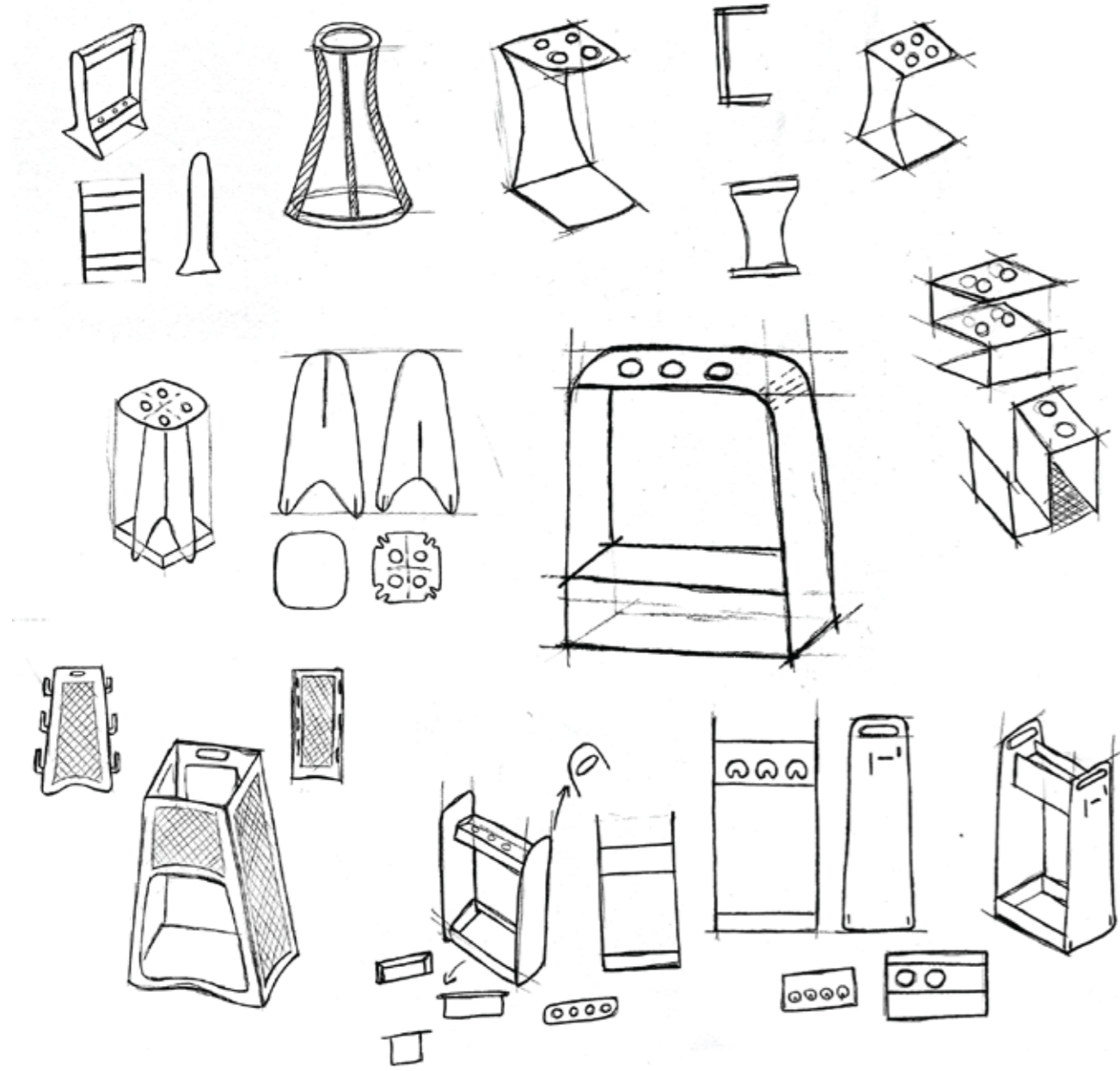



Designed by Özcan Düzce

# YEOLA

ŞEMSIYE STANDI



# Rabia Üçüncü

Erciyes Üniversitesi

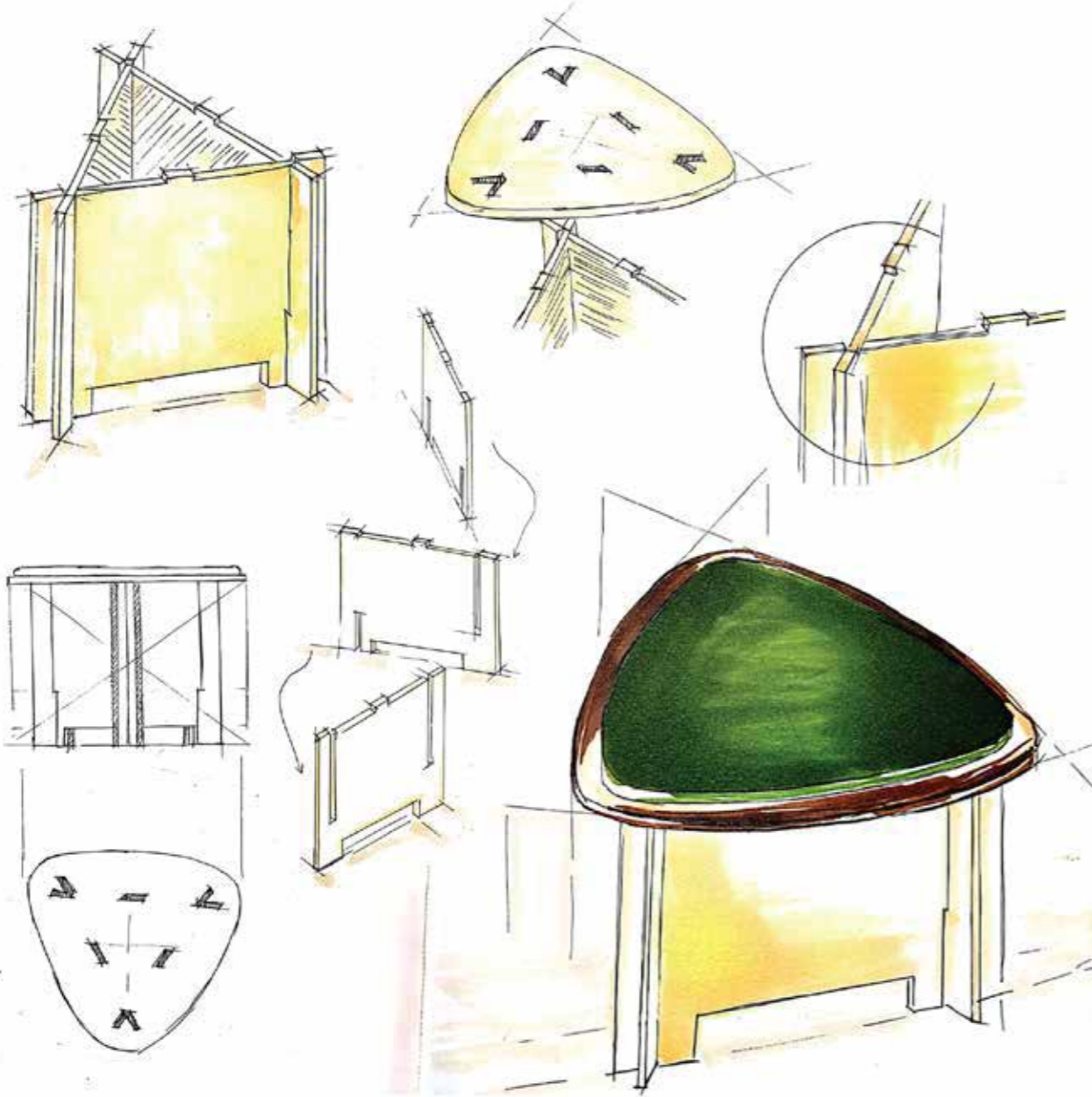



Designed by Rabia Üçüncü

# S(i)t-and

OTURMA BİRİMİ

# Şeyma Yıldırım

İstanbul Teknik Üniversitesi

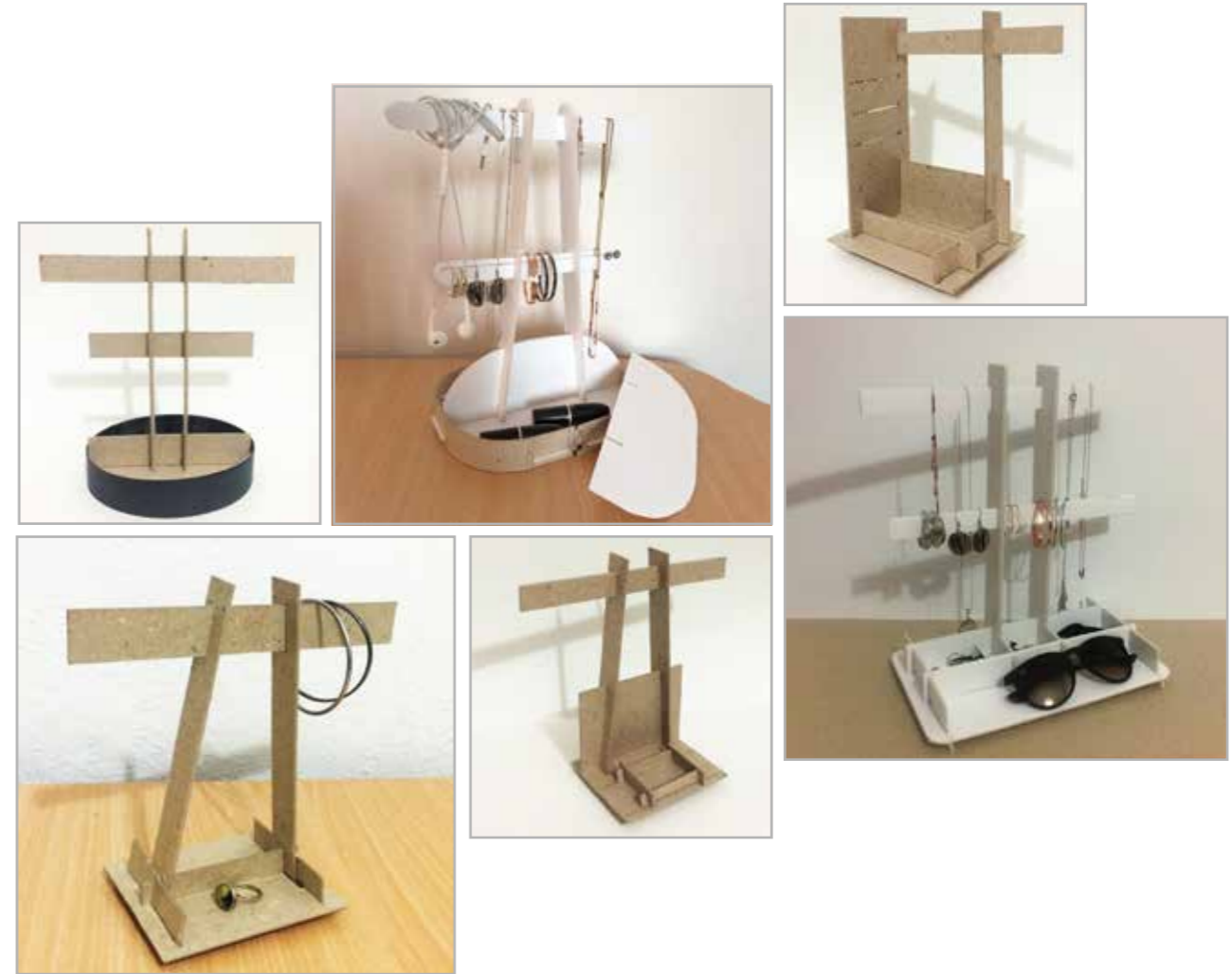
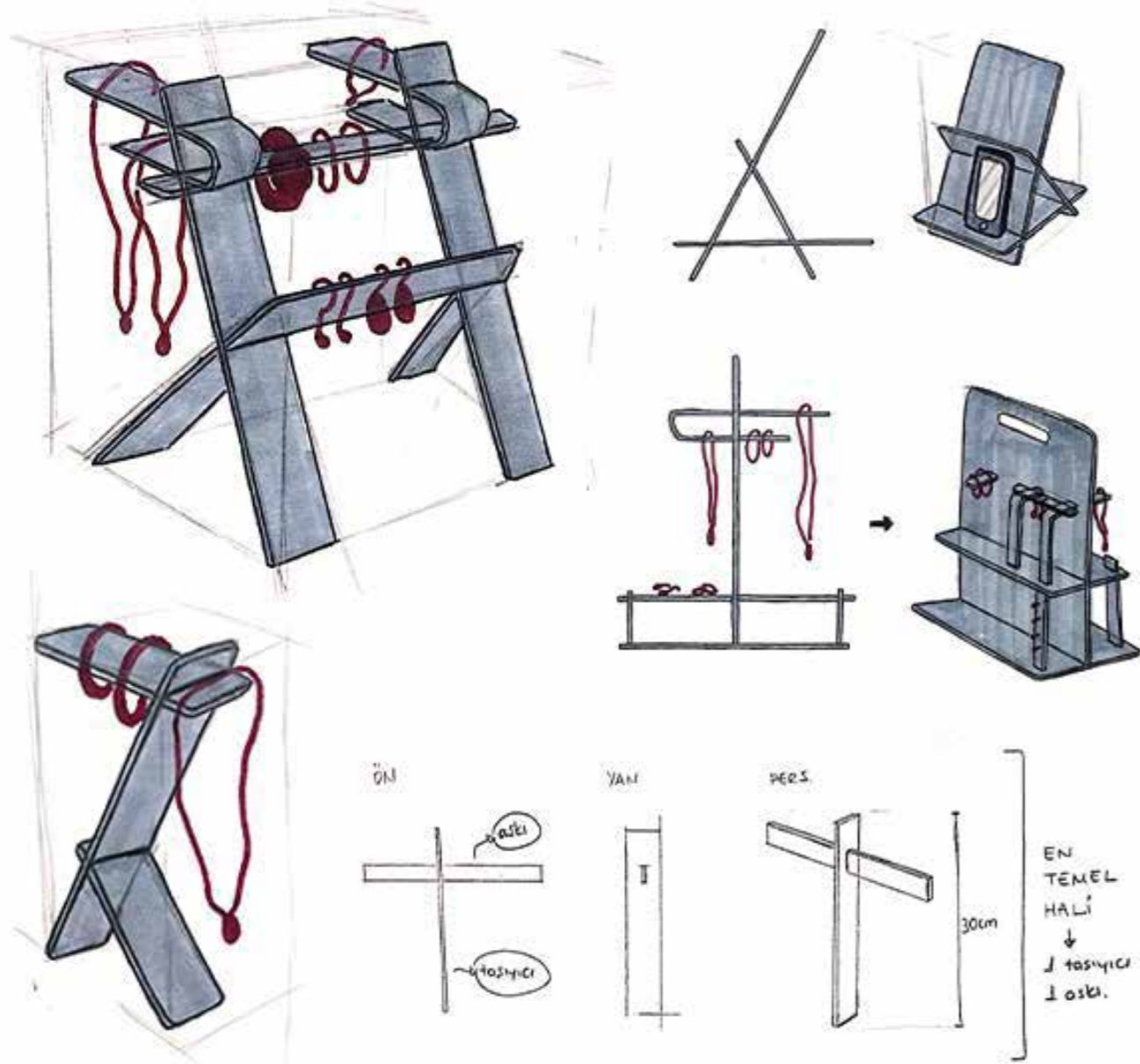



Designed by Şeyma Yıldırım

# PORTO

TAKI STANDI

# Ünal Özsoy

Okan Üniversitesi

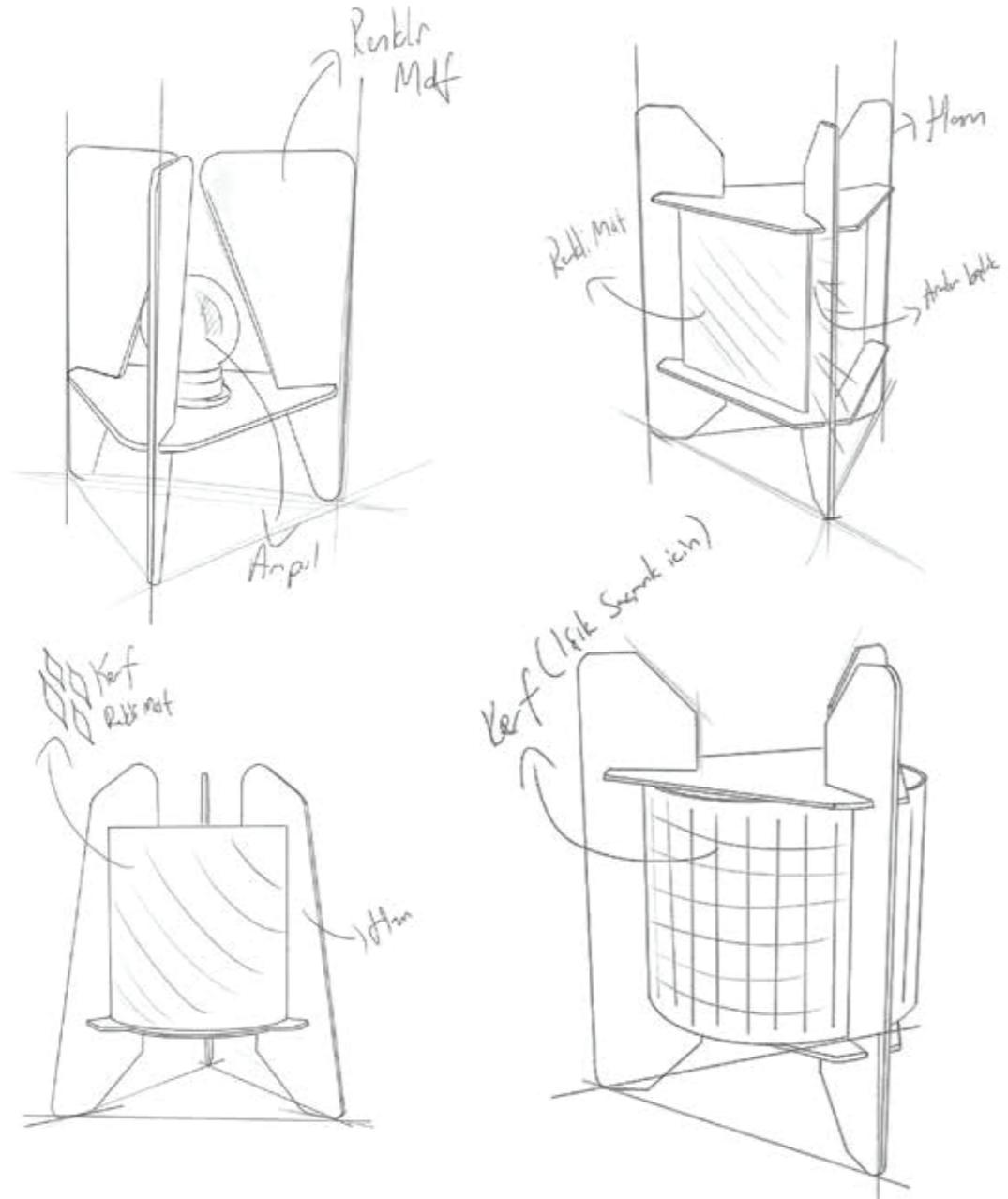



Designed by Ünal Özsoy

# SOFT

AYDINLATMA

# UGTW Hatırası

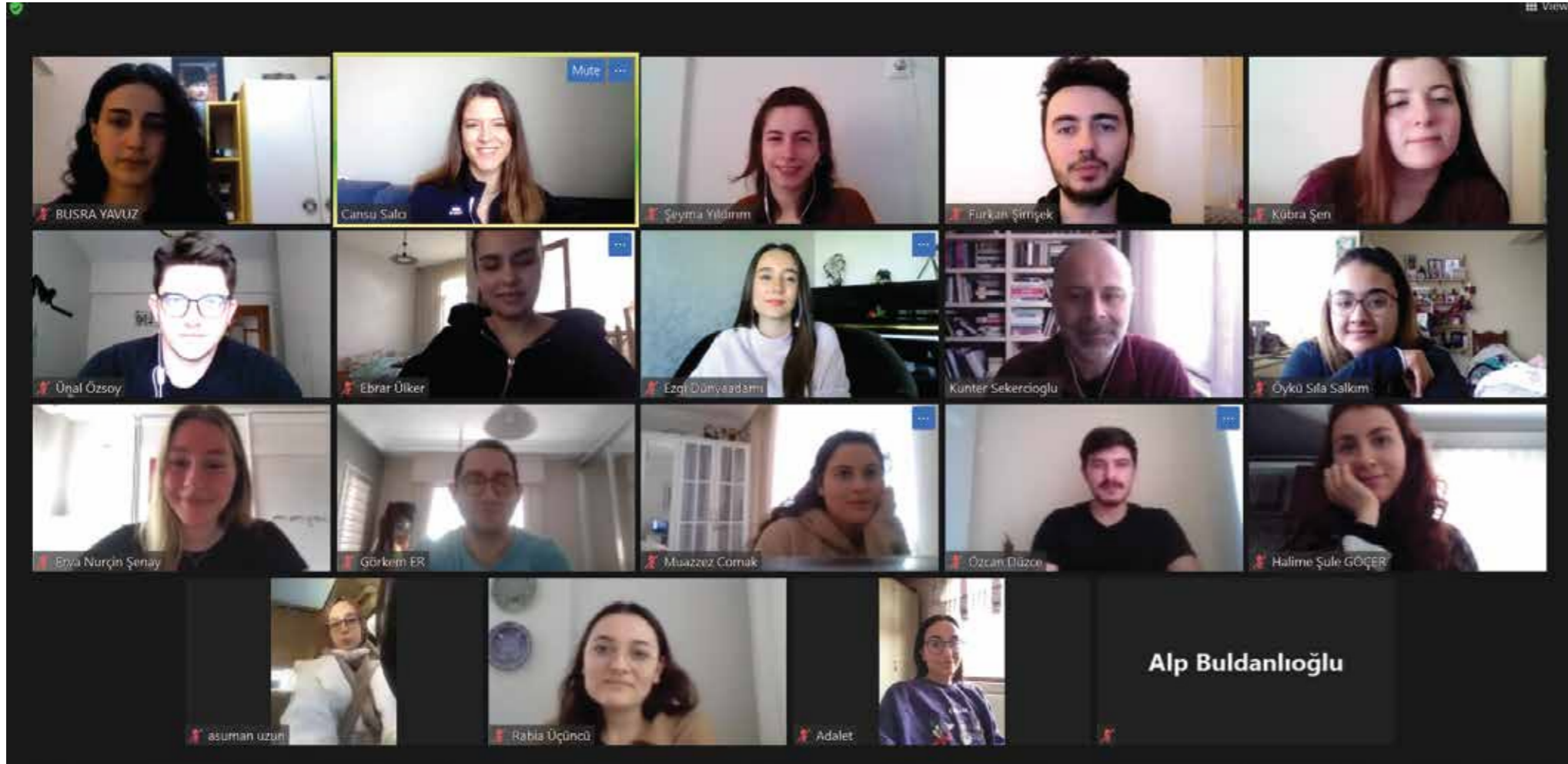

Tüm çalıştay ekibi olarak, bize bu deneyimi yaşama fırsatı verdikleri için **imos** 'a ve **sponsorlara** çok teşekkür ederiz.



**Ortak çalışma sürecimizde  
biriktirdiklerimiz**